

① PHYSICAL DIMENSION

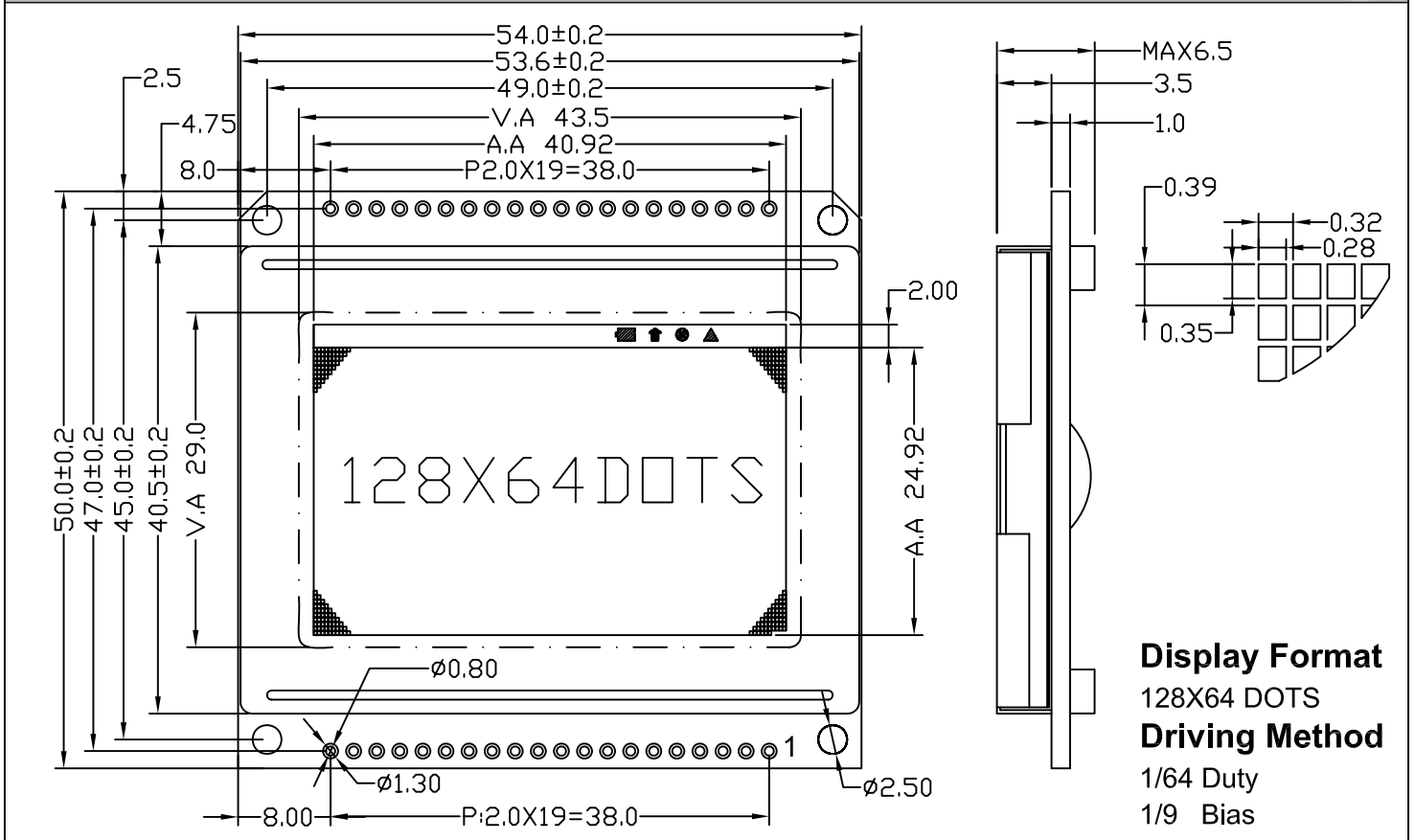

② MECHANICAL DATA

ITEM	SPECIFICATION	UNIT
Module Size With B/L (W X H X T)	54.0 X 50.0 X 6.5	mm
Viewing Area (W X H)	43.5 X 29.0	mm
Number of Dots (W X H)	128 X 64	dots
Dot Pitch (W X H)	0.32 X 0.39	mm
Dot Size (W X H)	0.28 X 0.35	mm
Weight	80.0 (With B/L)	g

③ PIN CONFIGURATION

ITEM	SYMBOL	DESCRIPTION	
1	VSS	Power ground	
2	VDD	Power positive (+5V±10%).	
3	V0	Operating voltage for LCD Driver(variable)	
4	A0	H:Data L:Instruction Code	
5	R/W	H:Read L: Write	
6	E	Enable trigger.	
7	DB0	Data bus [0~7]. These state I/O common terminal.	
14	DB7		
15	CS2		Chip 2 Select
16	CS1		Chip 1 Select
17	RES		System reset low active.
18	VEE		Supply Voltage for LCD Drive.
19	EL-ON		EL Backlight Enable
20	NC		No Connect

④ BLOCK DIAGRAM

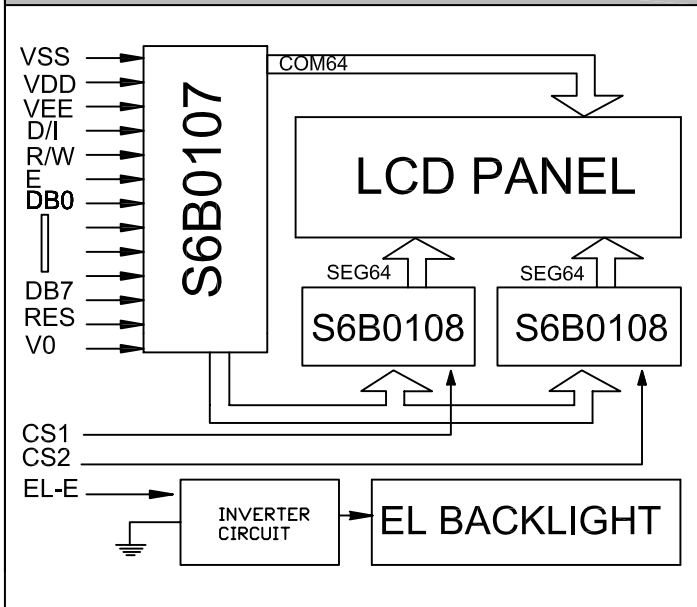

⑤ ABSOLUTE MAXIMUM RATINGS (25°C)

PARAMETER	SYMBOL	MIN.	MAX.	UNIT
SUPPLY VOLTAGE LOGIC	VDD	0	5.5	V
SUPPLY VOLTAGE DRIVER	VDD-VEE	0	15	V
INPUT VOLTAGE	VIN	0	VDD	V